



JMG Cranes s.r.l. a socio unico
"Società sottoposta ad attività di direzione e coordinamento di Compart Italia srl"

Sede Legale: Via Dante, 15 - 26100 CREMONA | Uffici e stabilimento: Via Sito Nuovo, 14 - 29010 Sarmato - PC - Italy
C.F. e p.iva 05896090965 | Capitale Sociale Euro 84.000,00 i.v.
T +39 0523 8486 | F. +39 0523 848000 | E. info@jmgcranes.com | www.jmgcranes.com

Edition 01/2016
© 2016 JMG Cranes srl All rights reserved

Pick&Carry Cranes



MC22S

ELECTRIC BATTERY OPERATED RADIO CONTROLLED CRANE
MAX CAPACITY 2,2 t



MC22S 2,2 t

DRIVING:	Front by nr. 2 electric motors 2kW 24V AC controlled by inverter, insulation class H
BATTERY:	24V 420Ah. Battery meter indicator on dashboard. Autonomy: 8 working hours
BRAKE:	Automatic braking system working on all wheels
DRIVING:	Radio remote controlling the proportionality of the movement and allowing the possibility of simultaneous movements of crane driving and steering; boom telescoping, raising/lowering and possible accessories
FRAME:	Fabricated from preformed and welded quality steel plate with built-in counterweight
WHEELS:	Front nr. 2 superelastic 18x7-8" Rear nr. 2 superelastic 15x4 1/2-8"
BOOM:	4 elements boom (1 fixed, 2 hydraulically telescoping complete with manual extension) fabricated from preformed and welded quality steel, sequential telescope by cylinder fitted with wear pads. Boom angle 60°/-15°
HYDRAULIC SYSTEM:	Powered by a silenced gear pump (3kW). Actuators controlled by an electro distributor operated by radio control, filter and safety valve. 22 MPa working pressure
STEERING:	90° + 90° rear steering by electric motor. Counter rotation system on front wheels
MOTOR PUMP:	Electric motor 3kW 24V DC, insulation class H
L.M.I.:	Electronic load moment indicator system complying to CE safety standards, complete with display showing: load lifted, maximum admitted load, tilting percentage, operating radius, angle, outreach and complete with warning lights of the operating status
WEIGHT:	Kg. 2050
OPTIONS ON REQUEST:	Hydraulic winch, manual or hydraulic jib, man basket, chain hoist, fork attachment, on board battery charger, watering system for battery, ATEX conversions, customer color, non-marking tires
CRANE CLASSIFICATION ACCORDING TO UNI ISO 4301-1:	A3
EU STANDARDS CE:	2006/42 CE MD - 2004/108 CE EMC - 2006/95 CE LVD - 2000/14 and subsequent modifications
REFERENCE STANDARDS:	EN 13000: 2010 UNI ISO 4301-2:2011 and subsequent modifications

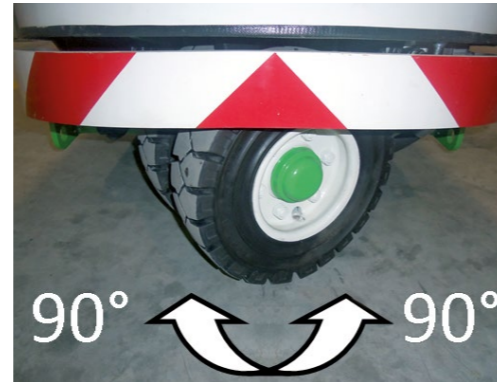

REAR 90°+90° AND COUNTER ROTATION SYSTEM ON FRONT WHEELS



RADIO REMOTE CONTROL



COMPACT DIMENSIONS



DASHBOARD

BASIC CRANE LOAD CHART

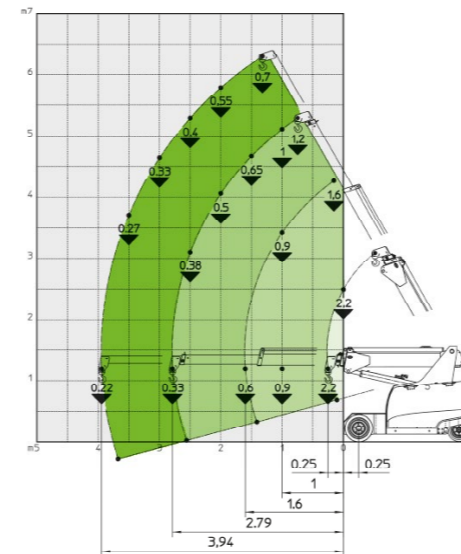

LOAD CHART HYDRAULIC WINCH

HYDRAULIC BOOM

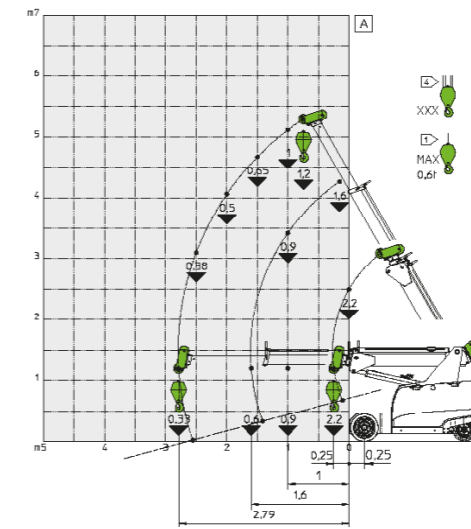

MANUAL EXTENSION

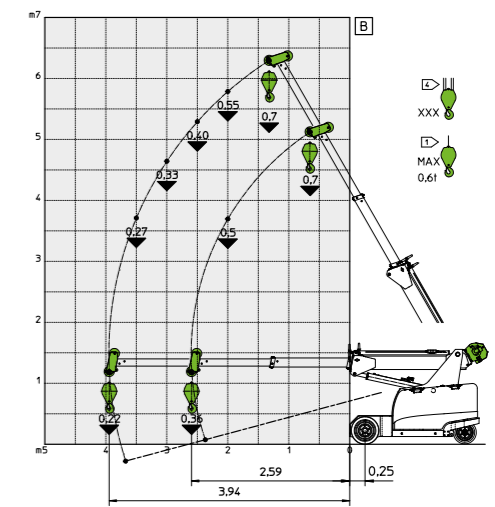

m-t

DIMENSIONS

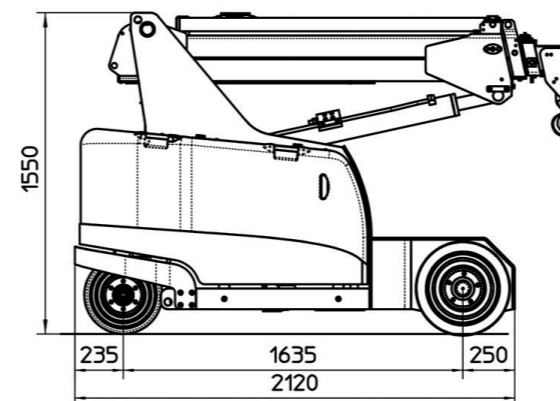

mm

